



BULK MATERIALS HANDLING PRODUCTS www.kinder.com.au

CAMBELT[®] HIGH INCLINE FLEXIBLE SIDEWALL CONVEYOR BELT

CAMWALL

Cambelt will design, fabricate, and build a new conveyor system to meet your specific conveyor needs. We also offer a full range of replacement belting for most existing conveyor systems.

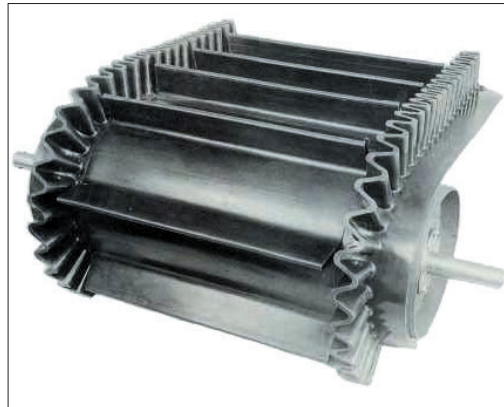

ONE-PIECE CONSTRUCTION

Flexible Sidewall Conveyor Belting, with the sidewall, the cleat and the base belt all simultaneously molded into a rugged, one piece homogeneously cured product, available only through Cambelt International Corporation.

In the past, these belts had to be molded and cured as three separate components, and bonded together to form the desired configuration.

Historically, the single biggest problem with this type of belt construction has been delamination or separation of the sidewall and/or cleat from the base belt when put under the stresses inherent in flexing around pulleys and being put under load.

Goodbye separation problems
- Hello one piece molded construction.

Kinder and Co. Pty. Ltd. Copyright © 2004 ABN 28 006 489 238

9 Jarrah Drive, Braeside, Victoria Australia, 3195 - P.O. Box 1026 Braeside, Victoria, Australia, 3195

 +61 (3) 9587 9244  +61 (3) 9587 9344  sales@kinder.com.au  www.kinder.com.au

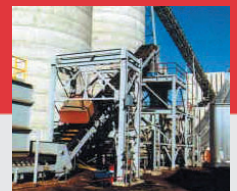



BULK MATERIALS HANDLING PRODUCTS www.kinder.com.au

CAMBELT® HIGH INCLINE FLEXIBLE SIDEWALL CONVEYOR BELT

Explanation of Typical Nomenclature

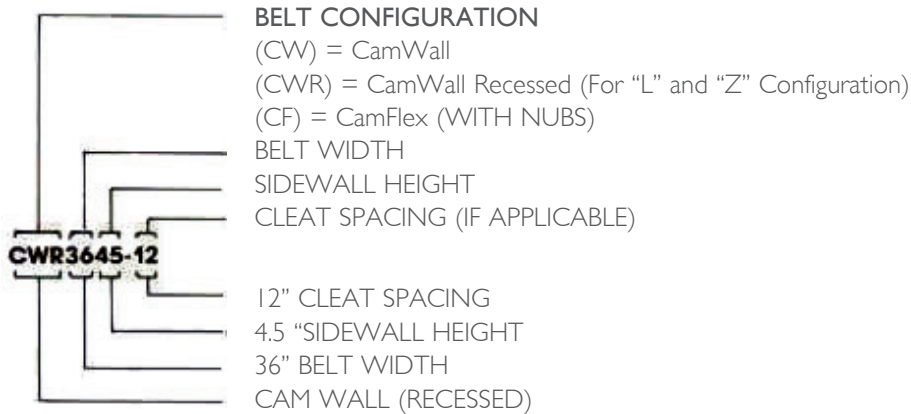

Belt Compounds

- | | |
|-----------------------------|---------------------------------|
| A – Black – General Purpose | B – Black – Oil & Fat Resistant |
| C – Black – Heat Resistant | D – Black – Flame Retardant |
| E – Black – MSHA Approved | F – Black – Conductive |
| G – White – Standard | H – White – Oil & Fat Resistant |

Belt Widths Available

Sidewall Height...3"	18"	24"	30"	36"				
Sidewall Height...4.5"	24"	30"	36"	42"	48"			
Sidewall Height...6"	24"	30"	36"	42"	48"	54"	60"	

Kinder and Co. Pty. Ltd. Copyright © 2004 ABN 28 006 489 238

9 Jarrah Drive, Braeside, Victoria Australia, 3195 - P.O. Box 1026 Braeside, Victoria, Australia, 3195

+61 (3) 9587 9244 +61 (3) 9587 9344 sales@kinder.com.au www.kinder.com.au





BULK MATERIALS HANDLING PRODUCTS www.kinder.com.au

CAMBELT[®] HIGH INCLINE FLEXIBLE SIDEWALL CONVEYOR BELT

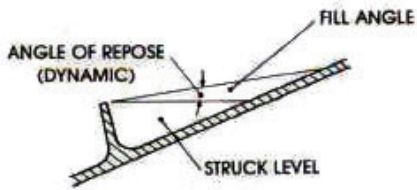

Theoretical Product Carrying Capacities

To obtain a volume per cleat, the theoretical carrying capacities are calculated by adding the area of the struck angle and the area of the fill angle (dynamic angle of repose) multiplied by the inside belt width. Cleat spacing and belt speed will vary the carrying capacity of the belt.

CamWall High Incline Flexible Sidewall Belt Conveyors

CamWall conveyors come in either heavy duty industrial construction or sanitary stainless steel construction with white food grade belt. They may be open or totally enclosed as required, to provide necessary environmental control, contain dust and fumes prevent contamination, or isolate the product from external atmospheric conditions. Enclosed and open conveyors are factory pre-assembled modular construction.

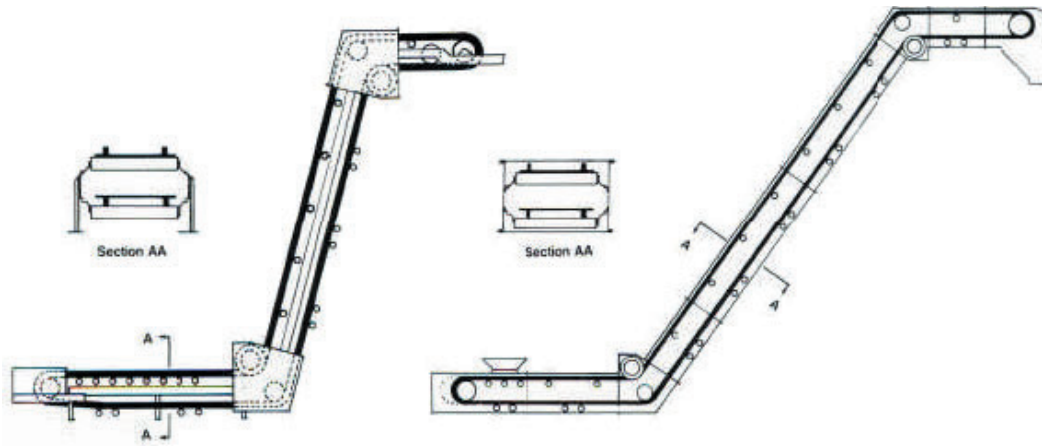

Kinder and Co. Pty. Ltd. Copyright © 2004 ABN 28 006 489 238

9 Jarrah Drive, Braeside, Victoria Australia, 3195 - P.O. Box 1026 Braeside, Victoria, Australia, 3195

+61 (3) 9587 9244 +61 (3) 9587 9344 sales@kinder.com.au www.kinder.com.au

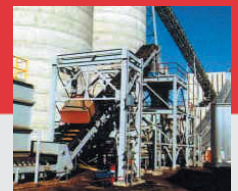



BULK MATERIALS HANDLING PRODUCTS www.kinder.com.au

CAMBELT[®] HIGH INCLINE FLEXIBLE SIDEWALL CONVEYOR BELT

CamFlex

Cambelt International Corp. once again demonstrates its leadership in the field of specialty belt conveyors. Backed by over 20 years of experience, and a solid reputation for quality products, innovative engineering and integrity, Cambelt offers a wide range of configurations and sizes in the unique camflex conveying system.

Cambelt's patented and proven equipment using our own fully molded CamFlex belting offers many advantages in both cost and operation. Take a look at what the Cambelt

CamFlex alternative can offer you; higher capacities, less product degradation, fewer dust control problems, and lower costs- and that means all costs... equipment costs, operating costs, and maintenance costs.

CamFlex fully molded flexible sidewall belts are unconditionally guaranteed against delamination of the sidewall from the basebelt. They don't come apart.



Kinder and Co. Pty. Ltd. Copyright © 2004 ABN 28 006 489 238

9 Jarrah Drive, Braeside, Victoria Australia, 3195 - P.O. Box 1026 Braeside, Victoria, Australia, 3195

+61 (3) 9587 9244 +61 (3) 9587 9344 sales@kinder.com.au www.kinder.com.au

