

# Conveyor Belt Skirting Worksheet

Conveyor Number:	Material Description:
Belt Speed (m/s):	Particle Size (mm) :
Trough Angle(°):	Particle Shape :
Belt Width 'A' (mm):	Moisture Contents:
Free Board 'B' (mm) :	Belt Specification (eg. Rubber PN150 etc.):
Chute Width 'C' (mm):	Belt Condition:
Chute to Belt Gap 'D' (mm) :	Belt Joining Type:      Hot/Cold Splice
Chute Wall Thickness 'E' (mm) :	Mechanical Fastener
Available Chute Height for Skirting Clamps 'F' (mm) :	Other
Skirting Length (mm) :	Are elevated temps involved?      Yes      No
Existing Skirting:	If Yes, what temperature?
Existing Skirting Clamping System Type?	Corrosive Environment?      Yes      No
	Current Problems:

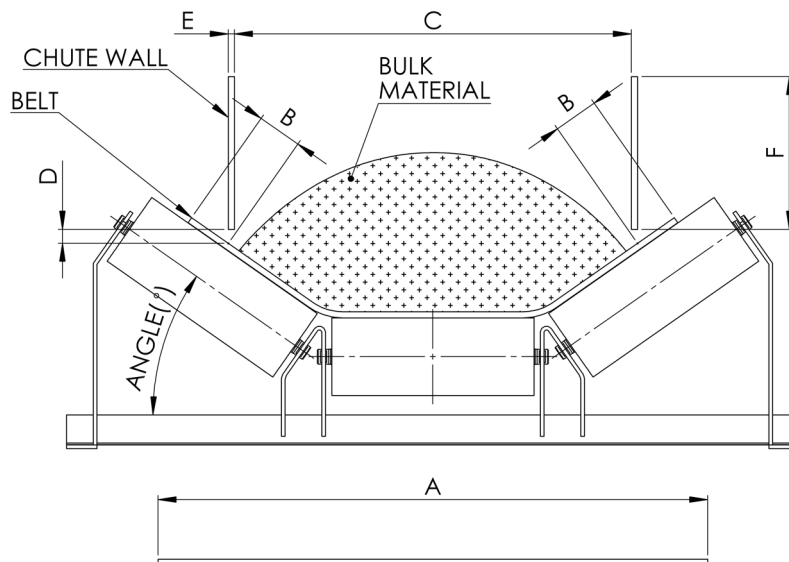

**K-WS-Conveyor Belt Skirting; Rev. 0;**

**Issue Date: 15/07/2013**

Issue 201611

Page 2



[www.kinder.com.au](http://www.kinder.com.au)

**Kinder Australia Pty Ltd**

P | +61 3 8587 9111      F | +61 3 8587 9101      E | sales@kinder.com.au

26 Canterbury Rd, Braeside VIC 3195 (PO Box 1026, Braeside VIC 3195)

abn 28 006 489 238



# Conveyor Belt Skirting Worksheet

## KINDER CONVEYOR BELT SKIRTING PRODUCTS

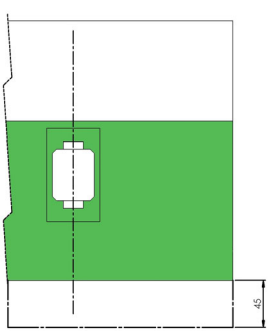

**K-Containment Seal**

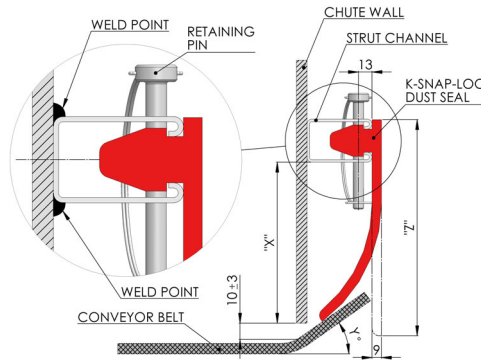
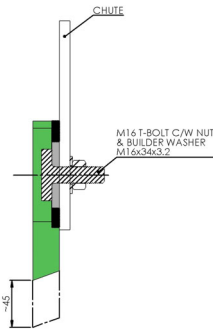

**K-Snap-Loc® Dust Seal**

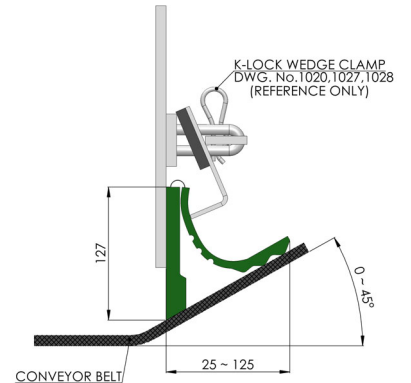

**K-Fold-N-Seal**

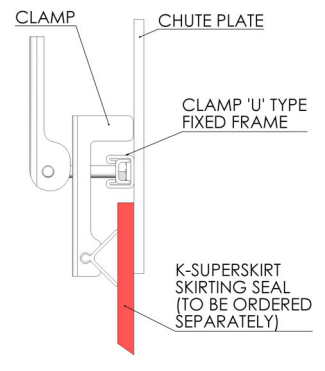
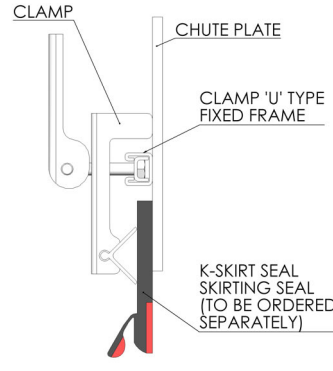
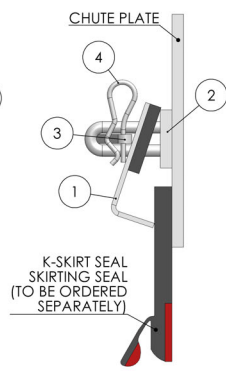
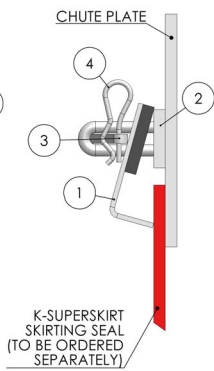
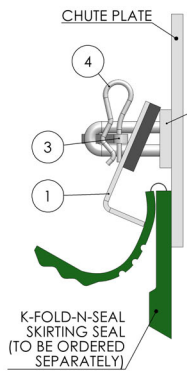

**K-Lock® Wedge Clamps**

**K- Quick Clamps**

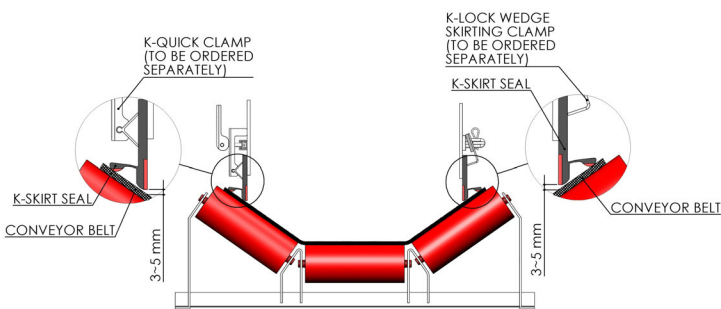

**K-Ultra Dual® Seal**

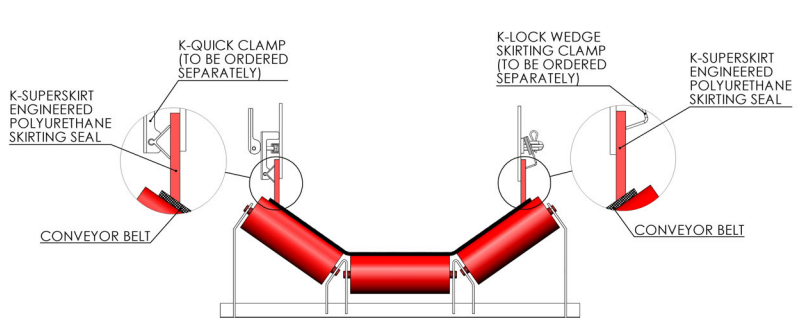

**K-Superskirt®**

## Conveyor Belt Skirting Worksheet

Name: \_\_\_\_\_

Company: \_\_\_\_\_

Site/Operation Location: \_\_\_\_\_

Contact Number: \_\_\_\_\_

Email: \_\_\_\_\_

Date: \_\_\_\_\_

Entered or Approved  
by Kinder Employee: \_\_\_\_\_

Kinder Document ID: \_\_\_\_\_

