

Conveyor Belt Skirting Worksheet

Conveyor Number:

Belt Speed (m/s):

Trough Angle(°):

Belt Width 'A' (mm):

Free Board 'B' (mm) :

Chute Width 'C' (mm):

Chute to Belt Gap 'D' (mm) :

Chute Wall Thickness 'E' (mm) :

Available Chute Height
for Skirting Clamps 'F' (mm) :

Skirting Length (mm) :

Existing Skirting:

Existing Skirting Clamping System Type?

Material Description:

Particle Size (mm) :

Particle Shape :

Moisture Contents:

Belt Specification (eg. Rubber PN150 etc.):

Belt Condition:

Belt Joining Type: Hot/Cold Splice
 Mechanical Fastener
 Other

Are elevated temps involved? Yes No

 If Yes, what temperature?

Corrosive Environment? Yes No

Current Problems:

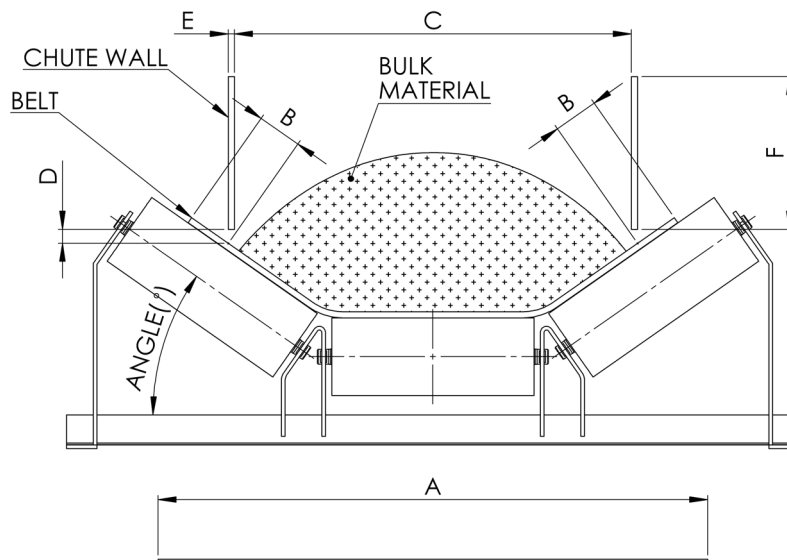

K-WS-Conveyor Belt Skirting; Rev. 0;

Issue 201611

Issue Date: 15/07/2013

Page 2



www.kinder.com.au

Kinder Australia Pty Ltd

P | +61 3 8587 9111 F | +61 3 8587 9101 E | sales@kinder.com.au

26 Canterbury Rd, Braeside VIC 3195 (PO Box 1026, Braeside VIC 3195)

abn 28 006 489 238



Conveyor Belt Skirting Worksheet

KINDER CONVEYOR BELT SKIRTING PRODUCTS

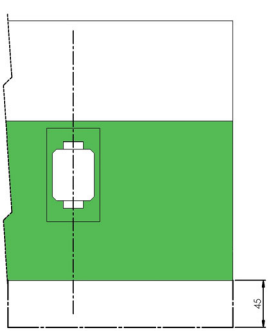

K-Containment Seal

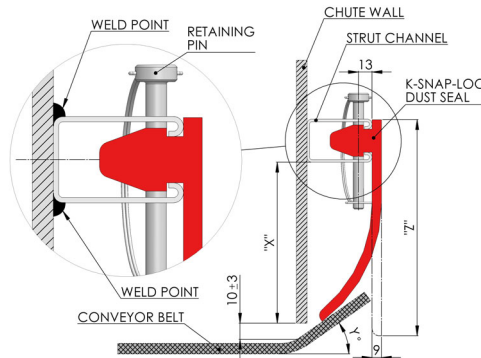
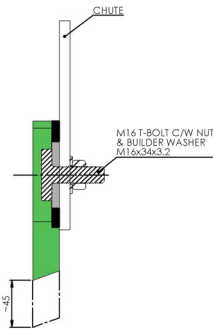

K-Snap-Loc® Dust Seal

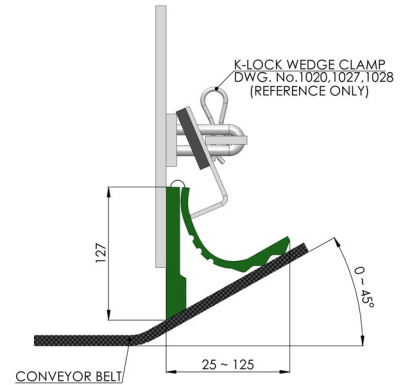

K-Fold-N-Seal

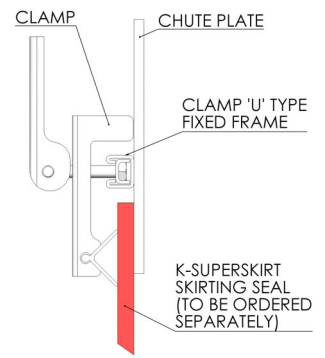
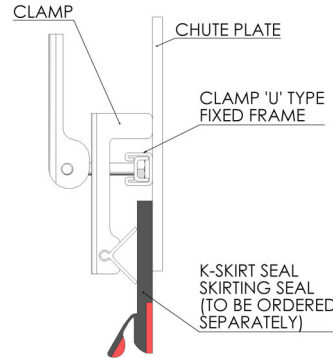
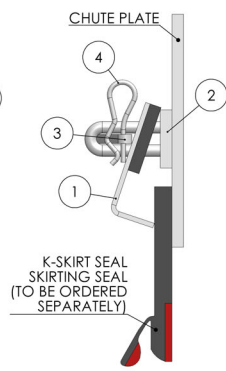
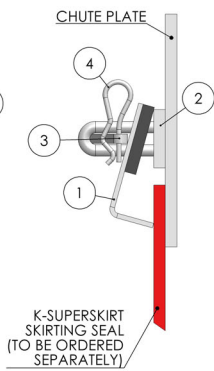
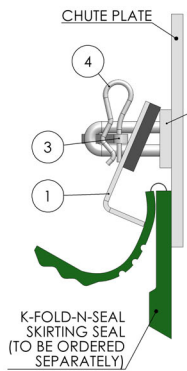

K-Lock® Wedge Clamps

K- Quick Clamps

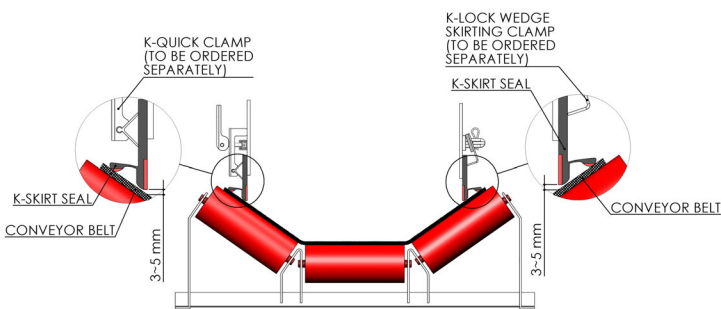

K-Ultra Dual® Seal

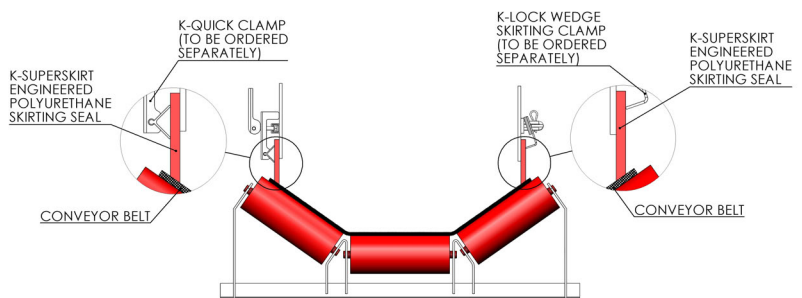

K-Superskirt®

Conveyor Belt Skirting Worksheet

Name: _____

Company: _____

Site/Operation Location: _____

Contact Number: _____

Email: _____

Date: _____

Entered or Approved
by Kinder Employee: _____

Kinder Document ID: _____

